

ML400 Double Ended Shearbeam



2500 lbs (12,000 kg)
 40,000 lbs (19,000 kg)
 50,000 lbs (23,000 kg)
 60,000 lbs (28,000 kg)
 75,000 lbs (34,000 kg)
 100,000 lbs (46,000 kg)
 125,000 lbs (57,000 kg)

Performance Specifications

Safe Overload	200%
Full Scale Output	3mv/V
Maximum Excitation	15 VDC
Non-Linearity	<0.03% FS
Hysteresis	<0.02%FS
Non-Repeatability	<0.01% FS
Thermal Sensitivity Shift	0.0008% of reading/°F
Thermal Zero Shift	0.0015% FS/°F
Barometric Effect	NIL
Bridge Resistance	700 Ω
Operating Temp Range	-40°C to +57°C

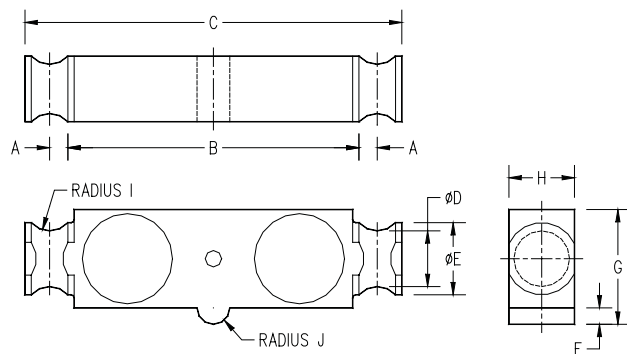

The ML400 is designed for center mounting and double link loading. This makes it ideal for truck and track scales.

It is available in nickel plated alloy steel. It is temperature compensated and completely environmentally protected.

Be assured of consistent, reliable, and accurate operation.



CC# 99-035
 nmax=10,000
 Class III L
 Multiple Cell

Capacity	A		B		C		D		E	
1k=1000lb	in	mm	in	mm	in	mm	in	mm	in	mm
40k/50k	0.50	13	6.25	159	8.25	210	1.63	41	2.00	51
60k/75k	0.75	19	8.50	216	11.50	292	1.70	43	2.20	56
100k/125k	1.00	25	10.50	267	14.50	368	2.44	62	3.20	81
Capacity	F		G		H		I		J	
1k=1000lb	in	mm	in	mm	in	mm	in	mm	in	mm
40k/50k	0.50	13	3.00	76	2.00	51	0.50	13	0.50	13
60k/75k	0.50	13	3.50	89	2.00	51	0.81	21	0.50	13
100k/125k	0.82	21	4.68	119	2.90	74	1.00	25	1.50	38

